

For further information and sales
t: +44(0)1706 878558
e: sales@mptgroup.com



KEY FEATURES

- ◆ High speed three thread over-locking heads
- ◆ Material run-out sensors
- ◆ Border widths from 75mm - 500mm
- ◆ Single side serging if required
- ◆ Thread management system for easy threading and all round access

BORDASERGE

Computer controlled border serge machine

The BordaSerge is an automatic system for serging both sides of any quilted or pre-stitched border up to 500mm in width. The finished border is collected on the variable speed rewind unit. Capable of serging 80 feet per minute. The BordaSerge is without doubt one of the fastest machines available.



High speed over-lock heads



For further information and sales
t: +44(0)1706 878558
e: sales@mptgroup.com



TECHNICAL SPECIFICATION

Material run-out sensor

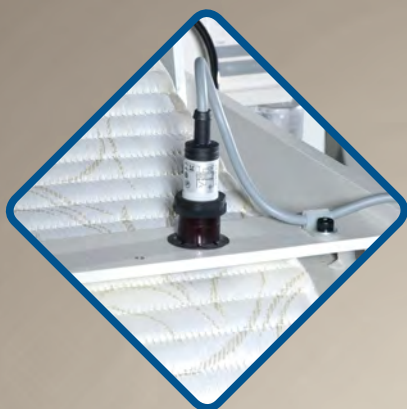

High speed over-locking heads



BORDASERGE
 Computer controlled border serge machine

MORE FEATURES & OPTIONS

- ◆ Production rate up to 4m per minute
- ◆ Access into machine protected by safety detectors
- ◆ Option available: BordaMark - measure and cut system
- ◆ Machine voltage: 415v
- ◆ Air requirement: 60-90psi

Sewing Head & Controls

Automatic needle positioning

Quick width adjustment

Electronic stitch length adjustment

Electronic flute width adjustment

Roller Operation

Rollers opened by pneumatic control for ease of loading

Automatic shut down sensor - detecting material blockage in roller

Auto rewind with quick release mandrel

Twin material clamping system

*FOOT PLATE DIMENSIONS

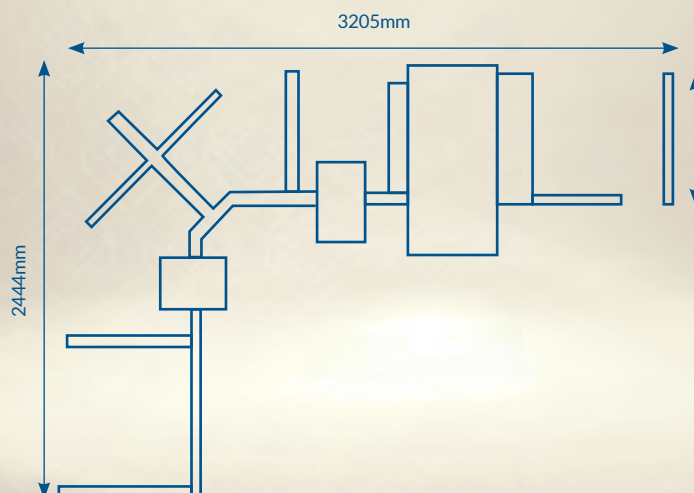

* May vary due to machine options and variations. For Full Automated Border Measure & Cut System see the BordaMark & Serge System

