

For further information and sales  
t: +44(0)1706 878558  
e: sales@mptgroup.com



## KEY FEATURES

- ◆ Massive memory for border programmes
- ◆ Input facility for size and quantity
- ◆ Material run-out monitoring system
- ◆ Stretch compensation factor control allows for varying degrees of stretch in the material because of filling thickness or material type
- ◆ Border widths from 75mm – 500mm

# BORDAMARK

## Computer controlled border mark and cut machine

This machine combines four important border production operations into one simple procedure. BordaMark automatically marks the border for later attachment of mattress handles, marks the border for the venting operation, measures the material to the required length and finally cuts the finished border – all in one pre-programmed operation.



For further information and sales  
**t: +44(0)1706 878558**  
**e: sales@mptgroup.com**



## TECHNICAL SPECIFICATION

## BORDAMARK

Computer controlled border mark and cut machine

### MORE FEATURES & OPTIONS

- ◆ Wider width machines available
- ◆ Massive memory for border programmes
- ◆ Input facility for size and quantity
- ◆ Material run-out monitoring system

Cutting



Optional notching

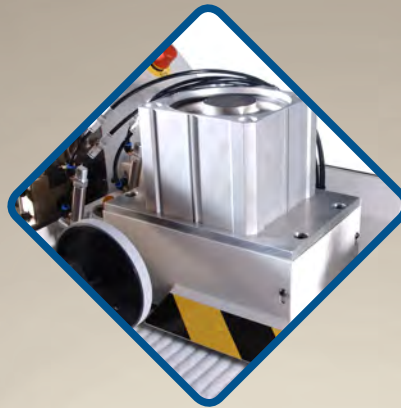

### Marking

Marks on the reverse edge to accommodate both horizontal and vertical handles

Selectable facility for the marking of handles or vents, or alternatively both simultaneously

Electronic stitch length adjustment

Slow motion mode for material width adjustment procedure following size change or material changeover

### Knife & Rollers

High speed rotary knife

Easy sharpening mechanism

Pneumatic roller opening for easy loading

Enclosed cutting area with safety sensor

### \*FOOT PLATE DIMENSIONS

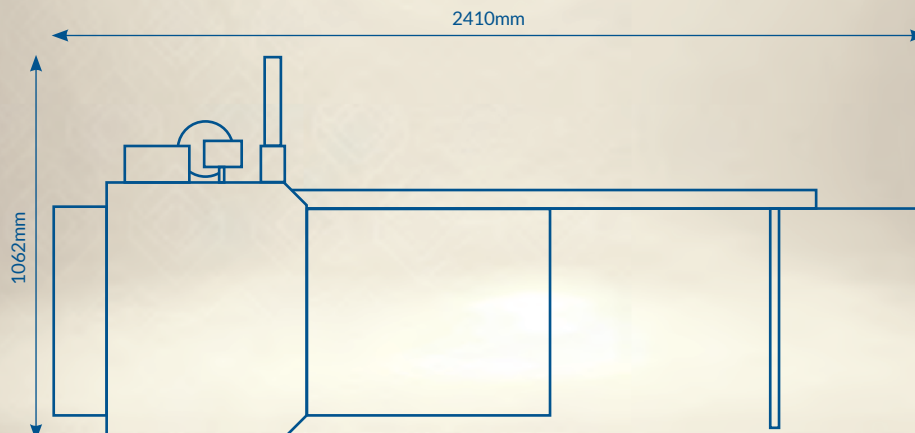

\* May vary due to machine options and variations. For Full Automated Border Measure & Cut System see the BordaMark & Serge System

